

InteliSys^{NTC} Hybrid

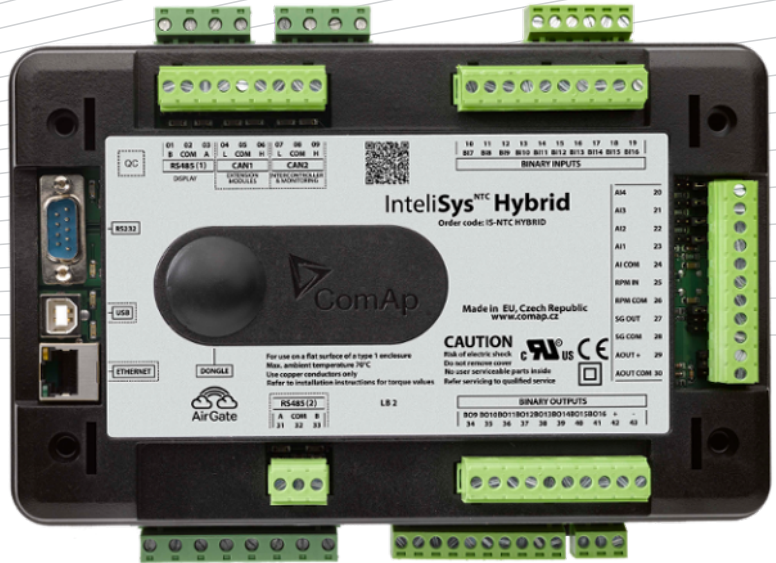

Order code: IS-NTC HYBRID
PV/Diesel hybrid controller

Datasheet

Product description

IS-NTC-Hybrid controller offers complex control of PV/Diesel hybrid applications. It allows smooth integration of renewable energy to conventional power generation from reciprocating gen-sets while maintaining high reliability, safety and efficiency of the site.

Key functions

- ▶ Full gen-set control with interface to PV inverters
- ▶ Inbuilt power management and load sharing
- ▶ Protection against gen-set underloading
- ▶ Dynamic spinning reserve calculation for maximized fuel savings
- ▶ Support of up to 100% renewable energy penetration*

Key features

- ▶ Extensive flexibility due to built-in PLC
- ▶ Interface with various site components (PV inverters, BMS, gen-set controllers, etc.)
- ▶ Smooth integration of renewable energy sources
- ▶ Fuel save function for optimum power management
- ▶ PV output control via analog output or Modbus
- ▶ Continuous monitoring of all sources of energy

- ▶ Inputs and outputs configurable for various customer needs
- ▶ Interface to remote display units (InteliVision 8, InteliVision 5 RD, InteliVision 17Touch)
- ▶ USB 2.0 slave interface
- ▶ Ethernet, Modbus and CAN communication
- ▶ Pre mortem history (50 records)
- ▶ Event-based history (up to 4000 records)
- ▶ 160 additional programmable protections

Application overview

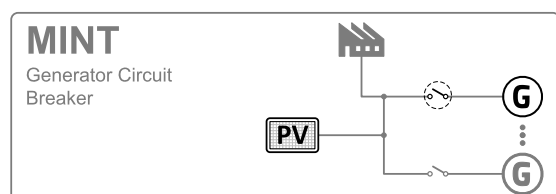
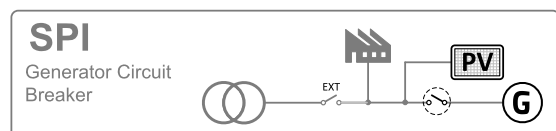
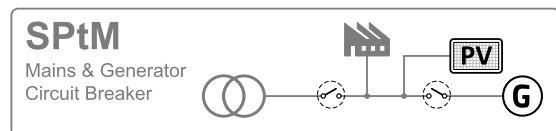

*if energy storage or weather prediction system is used

Technical data

Power supply

Power supply range	8-36 VDC
Power consumption	0.4 A / 8 VDC 0.15 A / 24 VDC 0.1 A / 36 VDC
RTC battery	10 years (replaceable by official service)
Fusing	2 A (without BOUT consumption)

Operating conditions

Operating temperature	-40°C to +70°C
Storage temperature	-40°C to +80°C
Operating humidity	95 % w/o condensation
Vibration	5 - 25 Hz, ± 1.6 mm 25-100 Hz, a = 4 g
Shocks	a=200 m/s ²

Voltage measurement

Measurement inputs	3 ph-n Gen voltage 3 ph-n Mains/Bus voltage
Measurement range	110V / 277V
Max allowed voltage	125 %
Accuracy	1 % of 110V / 277V
Frequency range	40-70 Hz (at accy 0.1 Hz)
Input impedance	0.6 M Ω ph-ph 0.3 M Ω ph-n

Current measurement

Measurement inputs	3 ph Gen current 1 ph Mains current
Measurement range	1A / 5A
Max allowed continuous current	1000% / 200%
Accuracy	2 % of 1A / 5A
Input impedance	< 0.1 Ω

Binary inputs

Number	4 non-isolated
Input resistance	4.7 k Ω
Close/Open indication	0 - 2 VDC close contact > 4 VDC open contact

Binary outputs

Number	4 non-isolated
Max current	0.5 A (2 A per group)
Switching to	negative/positive supply terminal

Analog inputs

Number	1 non-isolated
Type	Switchable (Voltage, Resistance, Current)
Resolution	10 bits, max 4 decimals
Range	0-5 VDC/0-2500 Ω /0-20 mA
Input impedance	>100 k Ω />100 k Ω /180 Ω
Accuracy	± 1 % of meas. value ± 1 mV ± 2 % of meas value ± 2 Ω ± 1 % of meas value ± 0.5 mA

Analog outputs

Number	1
Type	Switchable (Voltage, Current)
Range	0 - 10 VDC / 0 - 20 mA
Max current/load	5 mA/500 Ω
Accuracy	± 0.5 % of output value ± 20 mV ± 0.5 % of output value ± 100 μ A

Magnetic pick-up

Voltage input range	2 Vpk-pk to 50 V _{eff}
Frequency input range	4 Hz to 15 kHz
Frequency measurement tolerance	0.2 %

Voltage regulator output

Type	5 V TTL PWM / ± 10 VDC with IG-AVRi interface
------	---

Speed governor output

Voltage output	± 10 VDC / max. 15 mA
Voltage output via resistor	± 10 VDC via 10 k Ω resistor / max. 1 mA
PWM	500-3000 Hz / 5V / max. 10mA

Communications

RS232	Direct/Modbus, non-isolated
RS485	Direct/Modbus, isolated
Display port	non-isolated RS485, only terminal connection
USB port	Direct, isolated
Ethernet port	LAN/Internet, Modbus TCP, SNMP, WebServer, AirGate
CAN1	External modules 250 kbps, max 200 m, Isolated
CAN2	Intercontroller and comm extensions 250 / 50 kbps, max 200 / 1000 m, Isolated

Dimensions, terminals and mounting

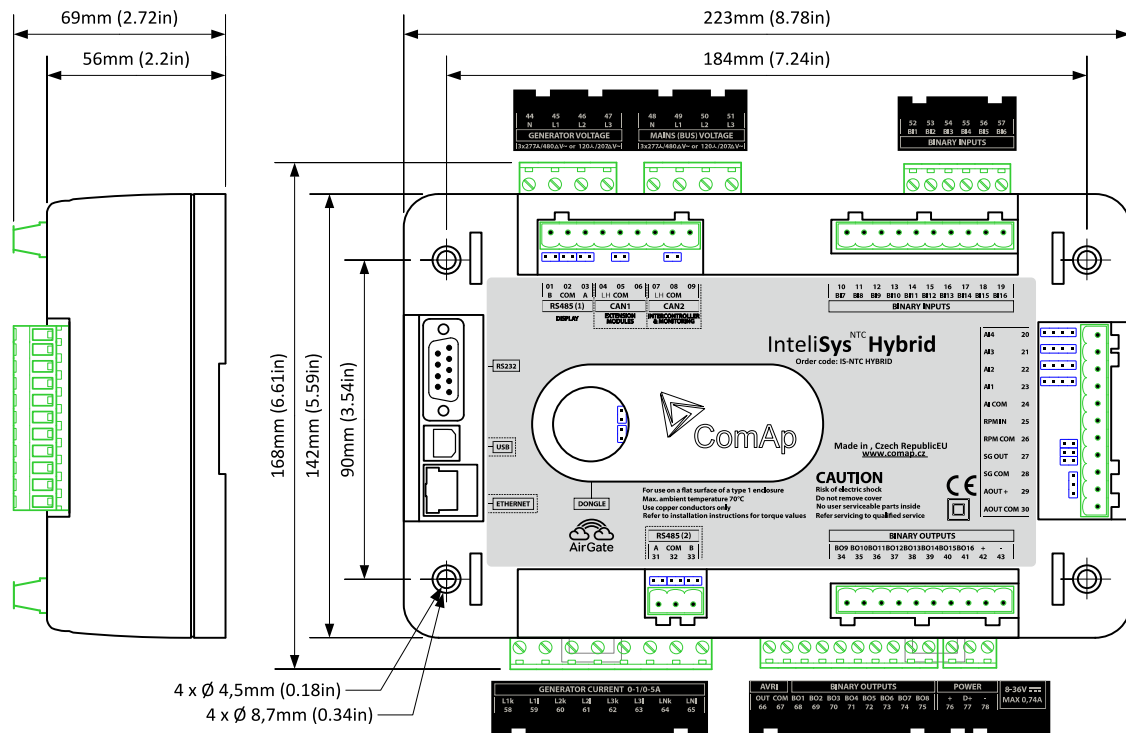

Panel door mounting with IntelliVision 5

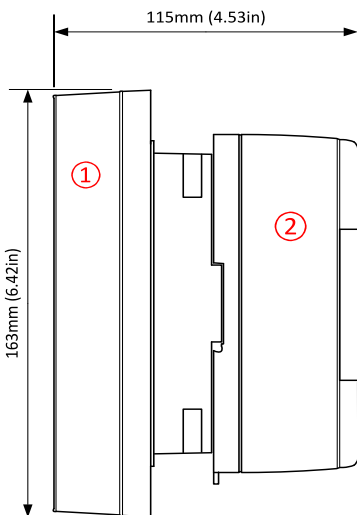

DIN-rail mounting

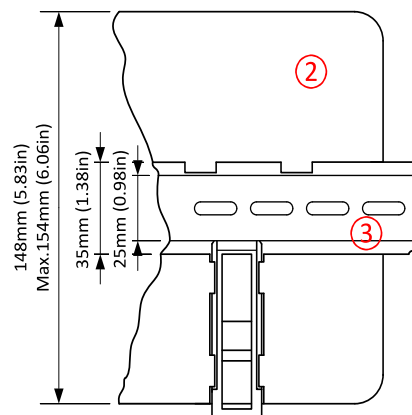

- ① IntelliVision5
- ② IntelliGen-NT-BaseBox
- ③ DIN-rail
- ④ IntelliVision 8

Panel door mounting with IntelliVision 8

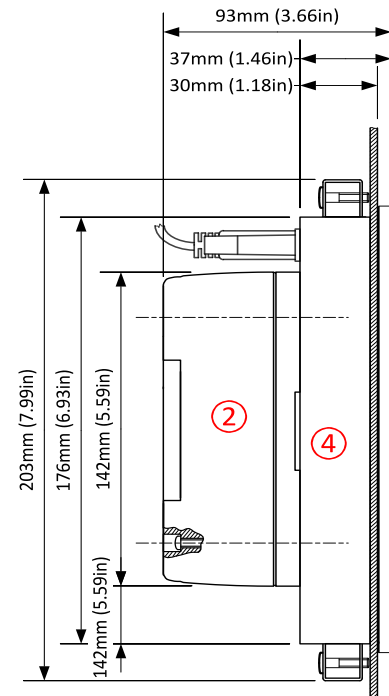

Note: IntelliSys^{NTC} Hybrid can be mounted on a standard DIN rail or, in combination with IntelliVision 5 or IntelliVision 8, it can be door mounted. IntelliVision 5 features mounting rail for direct mounting. Mounting in combination with IntelliVision 8 uses four screws provided in the IntelliSys^{NTC} Hybrid package.

Available Extension modules

Product	Description
Inteli IO8/8	8 Binary inputs, 8 Binary outputs and 2 Analog outputs packed in a small unit (HW switchable to IO16/0)
Inteli IO8/8	HW switchable to IO16/0 - 16 Binary inputs packed in a small unit
Inteli AIN8	8 Analog inputs (R, I, V) and 1 pulse/frequency input in a small unit
Inteli AIN8TC	8 Thermocouple Analog inputs in a small unit
Inteli AIO9/1	9 Analog inputs (4x DC, 4x thermocouples, 1x R) in a small unit
IS-AIN8	8 Analog inputs packed in a rugged metal unit
IGS-PTM	8 Binary inputs, 8 Binary outputs, 4 Analog inputs and 1 Analog output in a unit
IGL-RA15	15 Binary LED output (3 colors) packed in a rugged metal unit
I-AOUT8	8 Analog outputs packed in a rugged metal unit
InternetBridge-NT	Multiple Internet connections (PC and Modbus) to all controllers on CAN2 or RS485
I-LB+	Direct connection (PC) to all controllers on CAN2 or RS485

Related products

Product	Description
InteliVision 5	Color 5.6" display for monitoring and control
InteliVision 8	Color 8" display for advanced monitoring, control & trending, USB capable
InteliVision 17Touch	Color 17" touchscreen display designed for complete monitoring and control of multiple controllers or cogeneration installation.
ECON-4	Digital speed governor dedicated for speed control of gas or diesel engines.

Functions and protections

The product fully supports the following functions and protections as defined by ANSI (American National Standards Institute):

Description	ANSI code	Description	ANSI code	Description	ANSI code	Description	ANSI code
Synchronism check	25	Excitation loss	40	Overcurrent (IDMT)	51	AC reclosing	79
Undervoltage	27	Current unbalance	46	Earth fault current IDMT	51N+64	Overfrequency	81H
Overload	32	Voltage asymmetry and phase sequence	47	Power factor	55	Underfrequency	81L
Load shedding	32P	Temperature monitoring	49T	Overvoltage	59	ROCOF	81R
Reverse power	32R	Generator overcurrent	50	Gas (fuel) level	71		
Undercurrent	37	Earth fault current	50N+64	Vector shift	78		

Certificates and standards

This product is CE compliant.

▶ EN 60068-2-6 ed.2:2008

▶ EN 60068-2-30, May 2000

▶ EN 61010-1:2003

▶ EN 60068-2-27 ed.2:2010

▶ EN 60068-2-64



List of standards is available on: <https://webstore.iec.ch/>



Greenpower AB

Helsingborgsvägen Varalöv

262 96 Ängelholm

Tel: 0431 222 40

Fax: 0431 222 70

E mail: info@greenpower.se

web: www.greenpower.se